



**NAN HUA PRIMARY SCHOOL
MID-YEAR EXAMINATION 2021
PRIMARY 6**

SCIENCE

BOOKLET A

28 Multiple Choice Questions (56 marks)

Total Time for Booklets A and B : 1 hour 45 minutes

INSTRUCTIONS TO CANDIDATES

1. Write your name and index number in the space provided.
2. Do not turn over the page until you are told to do so.
3. Follow all instructions carefully.
4. Answer all questions.
5. Shade your answers in the Optical Answer Sheet (OAS) provided.

Marks Obtained

Booklet A		/ 56
Booklet B		/ 44
Total		/ 100

Name: _____ () **Class: P 6** _____

Date : 11 May 2021

Parent's Signature: _____

Section A: (28 x 2 marks = 56 marks)

For each question from 1 to 28, four options are given. One of them is the correct answer. Make your choice (1, 2, 3 or 4). Shade the correct oval (1, 2, 3 or 4) on the Optical Answer Sheet.

- 1 The table below shows the characteristics of animals A, B, and C.

Animals	Can fly	Has feathers	Lays eggs	Has 6 legs
A	✓		✓	✓
B		✓	✓	
C	✓	✓	✓	

Which of the following statements is correct?

- (1) A and C are birds.
- (2) B and C are birds.
- (3) A and B are insects.
- (4) A and C are insects.

- 2 The diagram below shows the life cycle of an insect.

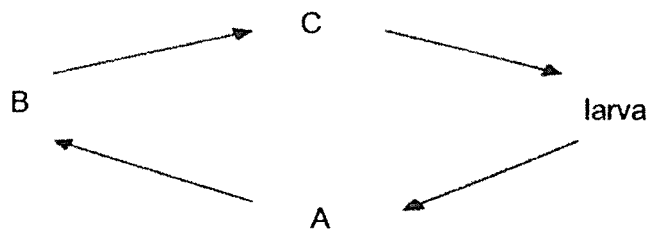

Which of the following shows the correct stages of its life cycle?

	A	B	C
(1)	Egg	Pupa	Adult
(2)	Pupa	Egg	Adult
(3)	Pupa	Adult	Egg
(4)	Adult	Egg	Pupa

3 Peter observed a single-cell organism under a microscope.

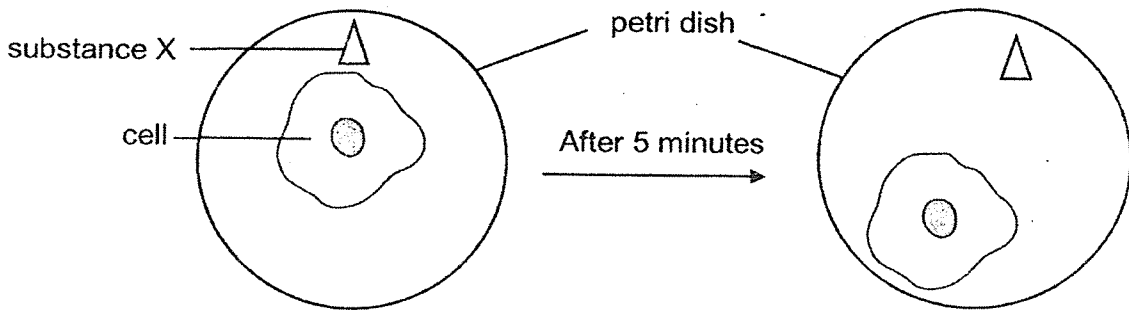

Which characteristics of living things does the above observation show?

- (1) grow
- (2) reproduce
- (3) need air, food and water
- (4) respond to changes around it

4 The picture below shows the side view of a flower.

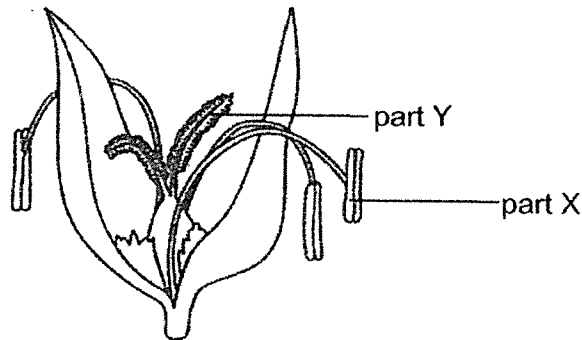

Which of the following correctly represents parts X and Y and the flower's method of pollination?

	Part X	Part Y	Method of pollination
(1)	anther	stigma	animals
(2)	stigma	anther	animals
(3)	anther	stigma	wind
(4)	stigma	anther	wind

- 5 The diagram below shows a cut fruit Z. Fruit Z is observed to contain many seeds.

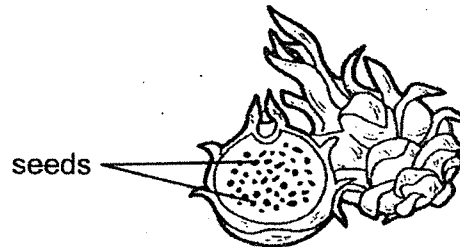

Based on the observation above, which of the following flower can be fertilised and will develop into the fruit shown above?

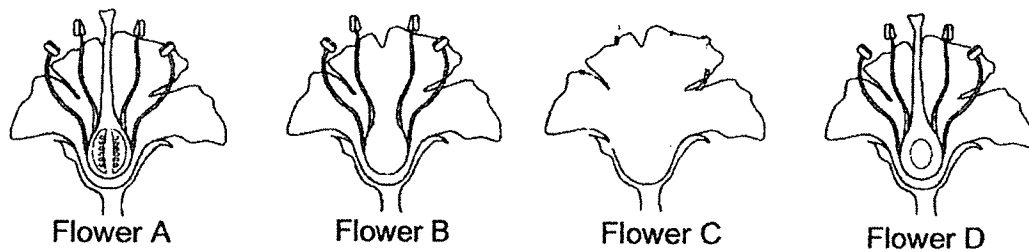

- (1) Flower A
- (2) Flower B
- (3) Flower C
- (4) Flower D

- 6 The diagram below shows the female human reproductive system.

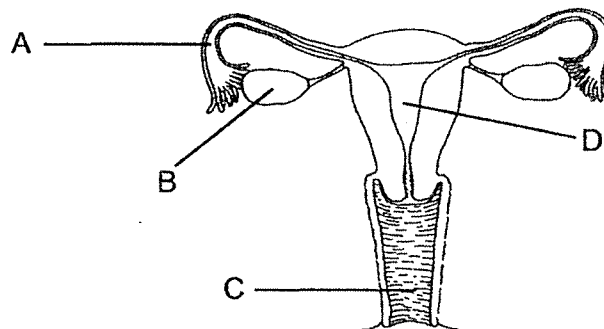

Based on the diagram, in which part does the development of the embryo take place?

- (1) A
- (2) B
- (3) C
- (4) D

- 7 A group of pupils made the following statements about the human digestive system.
- Ali : The gullet joins the mouth to the stomach.
- Betsy : No digestion of food takes place in the mouth.
- John : Undigested food is absorbed into the bloodstream.
- Steven : Digested food from the small intestine is passed to the large intestine.

Whose statement about the human digestive system is correct?

- (1) Ali
- (2) Betsy
- (3) John
- (4) Steven

- 8 The diagram below shows a plant with its food-carrying tubes removed at part X.

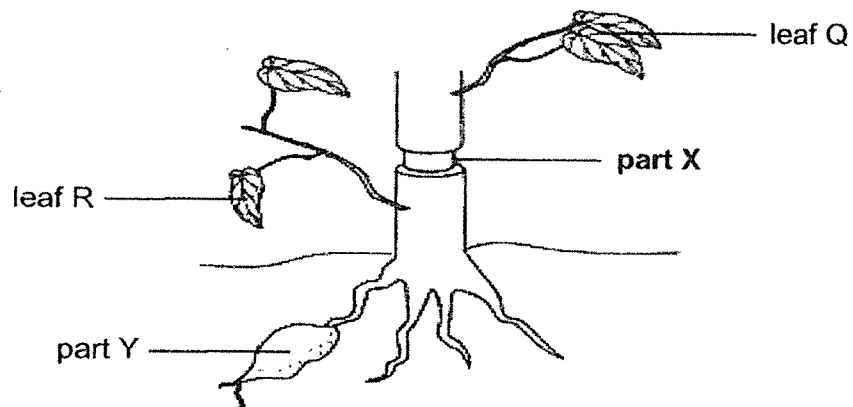

Based on the information provided above, which of the following statements are correct?

- A Leaf R will remain healthy.
- B Leaf Q will turn brown and die.
- C Part Y will become smaller after some time.
- D The parts of the stem above and below part X will appear swollen.

- (1) A and B only
- (2) A and C only
- (3) A and D only
- (4) B, C and D only

9 Study the diagrams below.

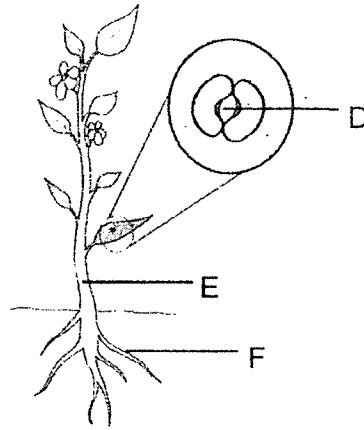
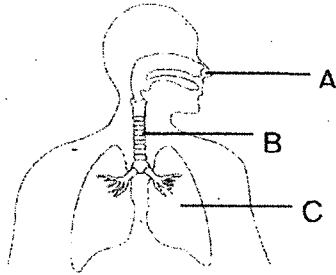

Which of the following parts allow the human and the plant to take in air from the surroundings?

	Human	Plant
(1)	A	D
(2)	B	E
(3)	C	D
(4)	C	F

10 The diagram below shows the movement of blood in some parts of a human body system.

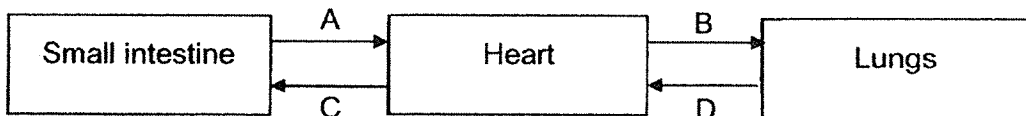

Which of the following correctly describes the oxygen, carbon dioxide and digested food in blood vessels A, B, C and D?

	Blood rich in digested food	Blood rich in oxygen	Blood rich in carbon dioxide
(1)	A	B	C
(2)	D	D	B
(3)	B	D	C
(4)	A	C	B

- 11 Tom conducted an experiment with a pot of plant. He tied a clear plastic bag around leaf A and put in a substance which absorbed carbon dioxide.

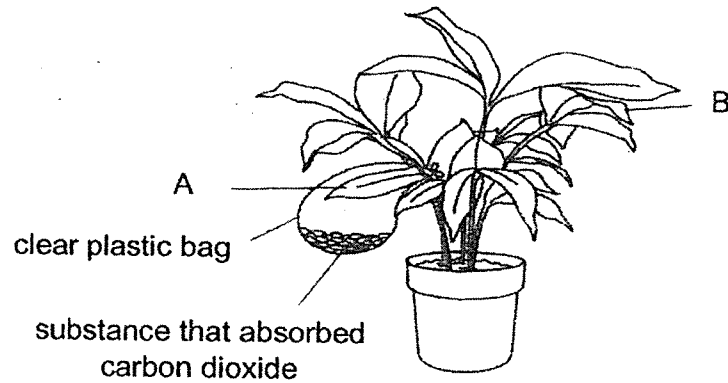

After some time, he tested both leaves A and B for the presence of food. Based on Tom's experiment, he wanted to find out if leaves _____.

- (1) need light to make food
 - (2) need carbon dioxide to make food
 - (3) need light and carbon dioxide to make food
 - (4) need oxygen and carbon dioxide to make food
- 12 Adele counted the following organisms on a tree.

Organism	Number of organisms
Ladder fern	2
Spider	3
Ant	15
Caterpillar	5
Butterfly	4
Lizard	8
Sparrow	7

Which of the following statements are correct?

- A The organisms above form one community.
 - B The organisms above live in the same habitat.
 - C Ants form the largest population size on the tree.
 - D There are seven populations of organisms on the tree.
- (1) A and B only
 - (2) C and D only
 - (3) A, B and C only
 - (4) A, B, C and D

13 The diagram below shows a pond and the different organisms living in it.

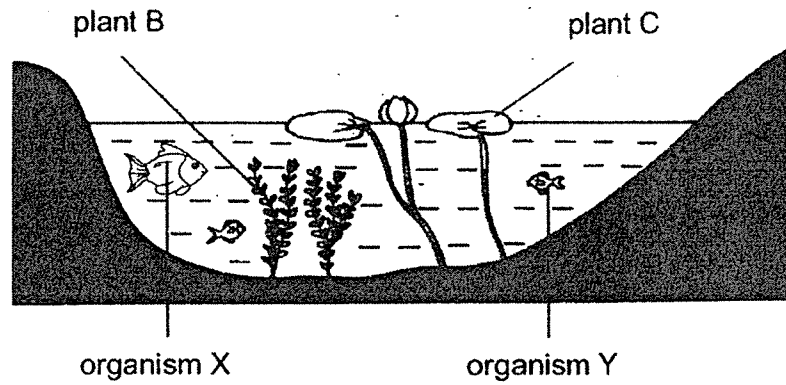

The food chain below shows the relationships between some of the organisms in the pond.



Which of the following could cause the population size of Plant B to increase?

- A a decrease in the population size of plant C
 - B a decrease in the population size of organism Y
 - C an increase in the population size of organism Y
 - D an increase in the population size of organism X
- (1) B only
(2) A and C only
(3) A, B and C only
(4) A, B and D only

- 14 Study the food web below. It shows the food relationships between the organisms in a garden community.

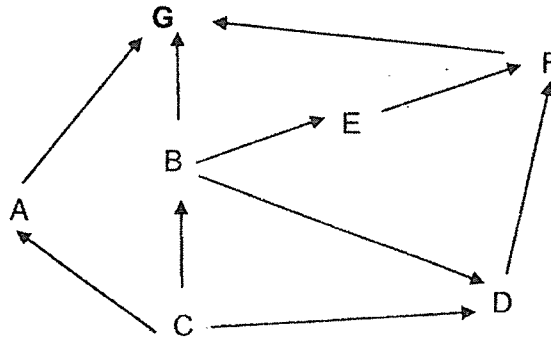

Which of the following statements describe organism G?

- (1) It is a food producer.
 - (2) It is a consumer and eats animals only.
 - (3) It competes with organisms C, D and E for food.
 - (4) It is a decomposer and feeds on the dead organisms.
- 15 Study the flowchart below.

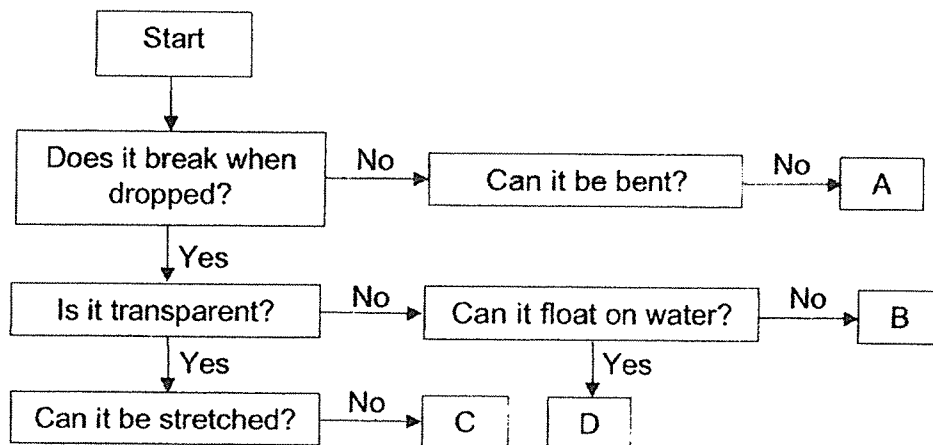

Which material is most suitable to make a clear window?

- (1) A
- (2) B
- (3) C
- (4) D

16 Zack wants to find out whether two materials, X and Y, float or sink in water.

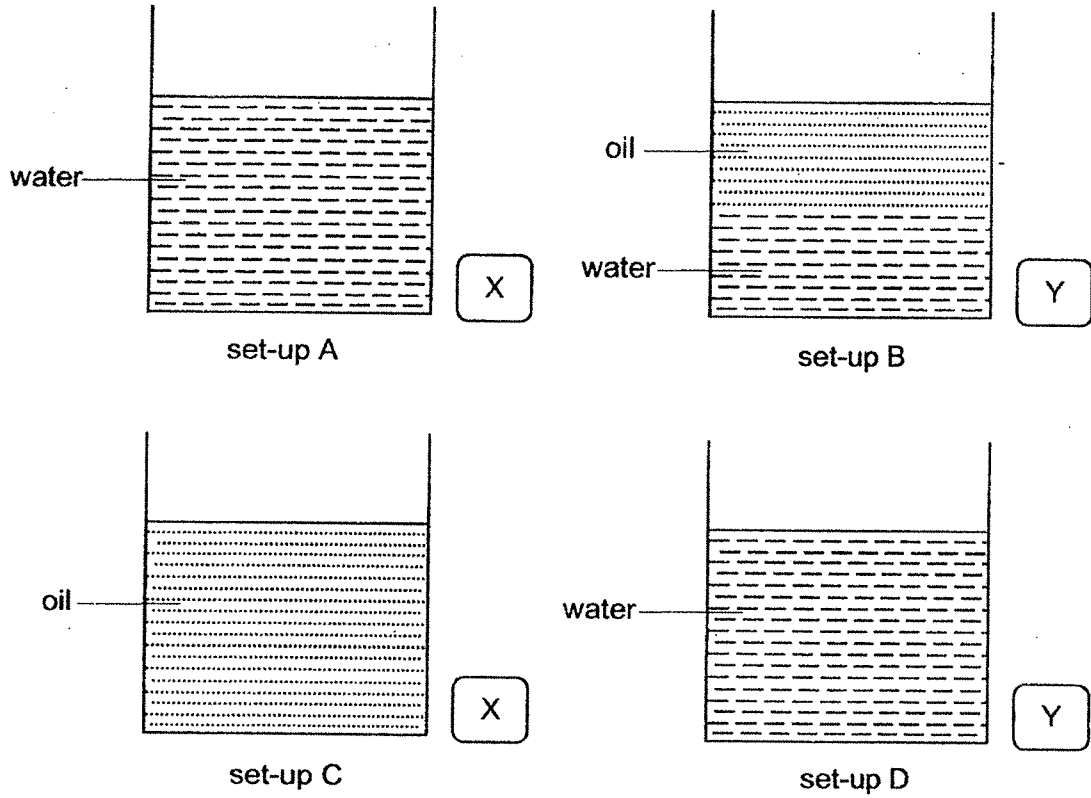

Which of the following two set-ups should Zack use?

- (1) A and B
- (2) A and D
- (3) B and C
- (4) C and D

- 17 Tim poured 25 ml of water into each of three measuring cylinders. He then placed three different objects, X, Y and Z, into the cylinders as shown in the diagram below.

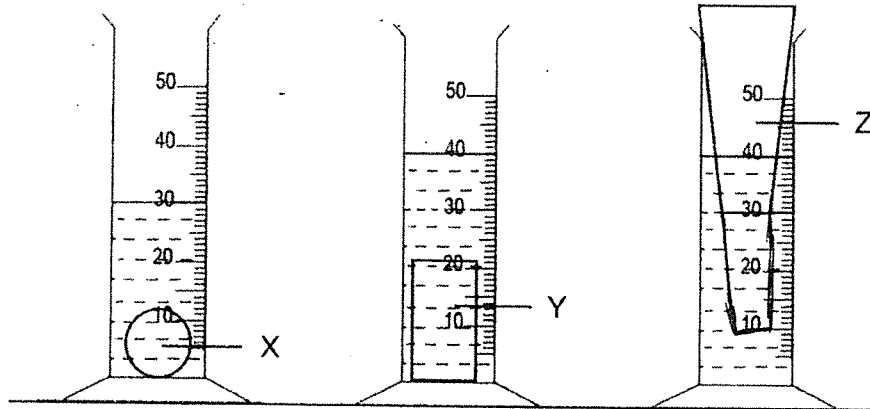

Based on his observations, which of the following conclusions are correct?

- A Object Z has the largest volume.
 - B Object Y has a larger volume than X.
 - C Object Y and Z have the same volume.
- (1) A and B only
(2) A and C only
(3) B and C only
(4) A, B and C

18 Study the diagram below.

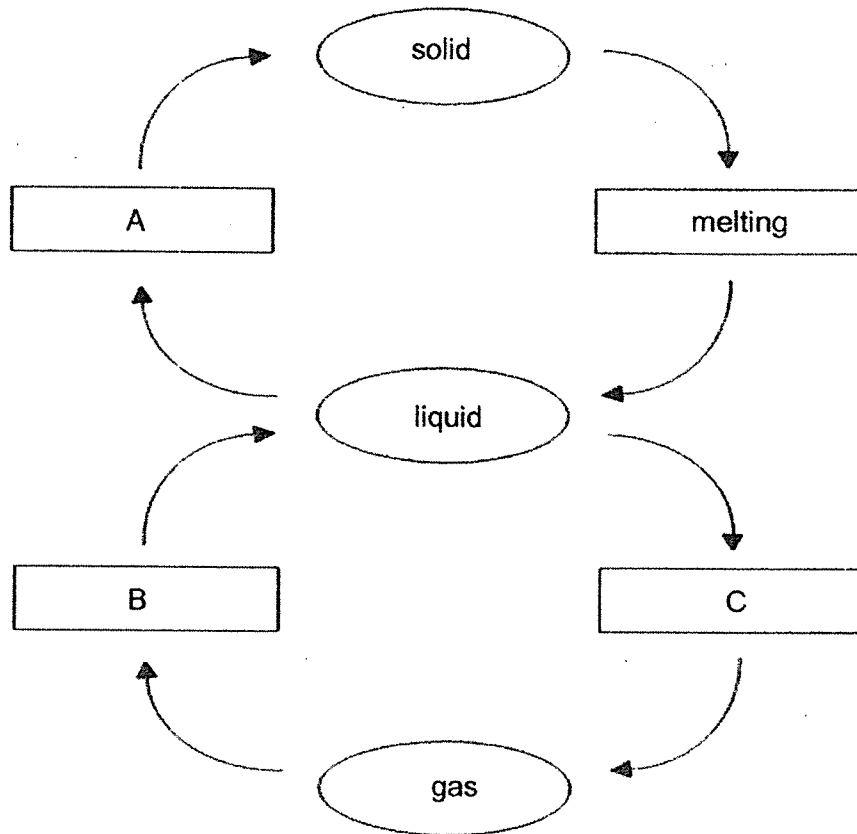

Which one of the following correctly shows the processes of A, B and C?

	A	B	C
(1)	freezing	condensation	evaporation
(2)	freezing	evaporation	condensation
(3)	condensation	freezing	evaporation
(4)	condensation	evaporation	freezing

- 19 The melting point and boiling point of substance Q are 20 °C and 110 °C respectively.

Substance Q was heated in a pot for 20 minutes. The temperatures of substance Q before and after heating are shown in the table below.

Time (min)	Temperature of substance Q (°C)
0	15
20	100

Based on the above experiment, which of the following shows the correct state of Q at the two intervals?

	State of Q at the start of heating	State of Q after 20 minutes of heating
(1)	liquid	gas
(2)	liquid	liquid
(3)	solid	liquid
(4)	solid	gas

- 20 Hans created a circuit using identical bulbs, batteries, wires and switches. The circuit is as shown below.

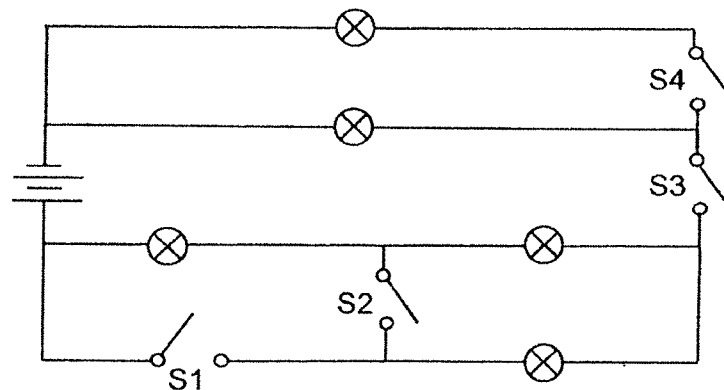

Which pairs of switches, when closed, will cause only four bulbs to light up?

- A S1 and S2
- B S1 and S3
- C S2 and S3
- D S3 and S4

- (1) A and B only
- (2) C and D only
- (3) A, B and C only
- (4) B, C and D only

- 21 Susanne wanted to find out the connections of 6 points U, V, W, X, Y and Z on the circuit card below using a circuit tester.

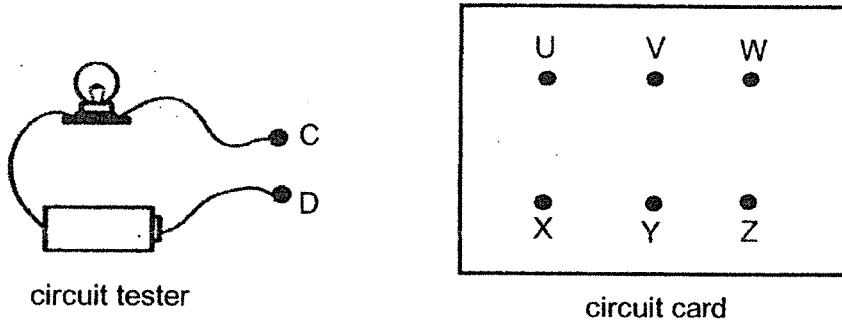

She connected ends C and D of the circuit tester to the various pairs of points on the circuit card. The results were recorded in the table below.

Points tested	UV	UX	UY	UZ	XZ	WZ
Bulb lit	Yes	No	Yes	Yes	No	No

Which of the following shows how the circuit card was connected ?

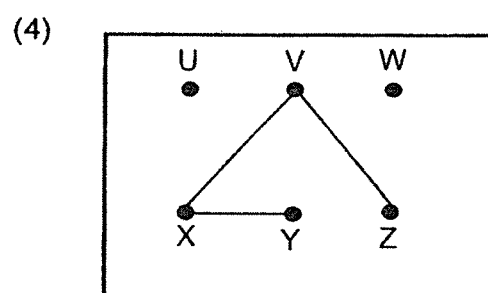
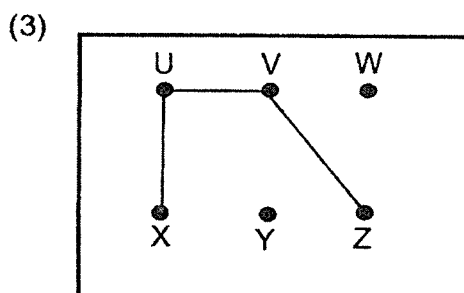
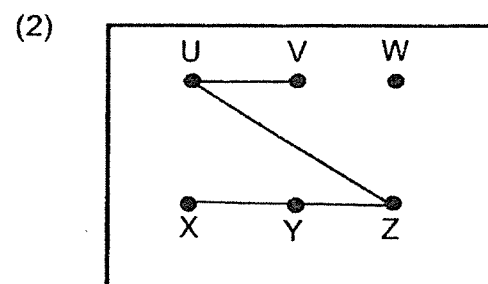
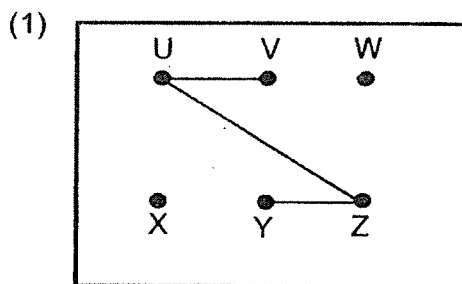

- 22 The diagram below shows a mirror and a wooden block placed between a torch and a screen in a dark room.

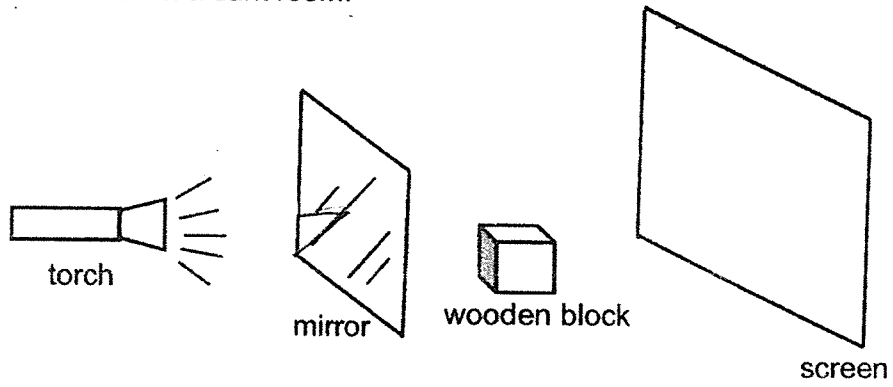

Which of the following correctly shows the shadow cast on the screen?

(1)



(2)

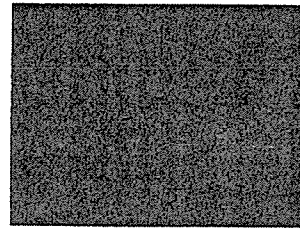

(3)



(4)

- 23 Amy set up an experiment as shown below. She placed similar ice cubes X, Y and Z into similar containers containing different amounts of water at 50 °C.

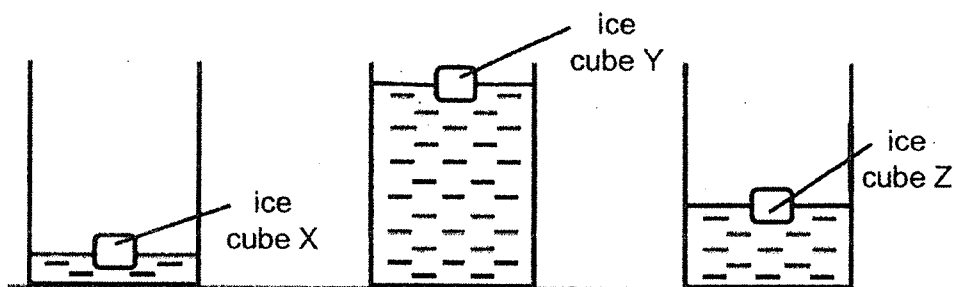

Based on Amy's experiment, which of the following shows the correct order in which the ice cubes X, Y and Z are likely to melt completely?

	slowest	→	fastest
(1)	Y		Z
(2)	Y		X
(3)	X		Y
(4)	X		Z

- 24 Four balls of the same mass are placed on four separate wooden blocks with different heights as shown below.

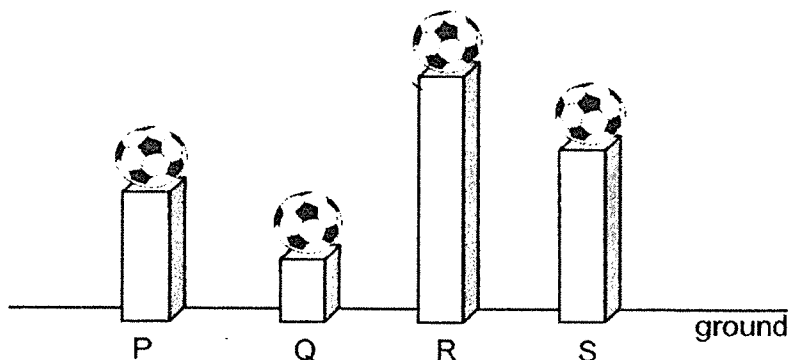

Each ball is then pushed off the wooden block with equal strength and allowed to bounce on the ground until it stops bouncing eventually and comes to a complete rest.

Which ball will take the longest time to come to a complete stop?

- (1) P
- (2) Q
- (3) R
- (4) S

- 25 A ball which is tied to a string swings from A to B and then to C as shown below.

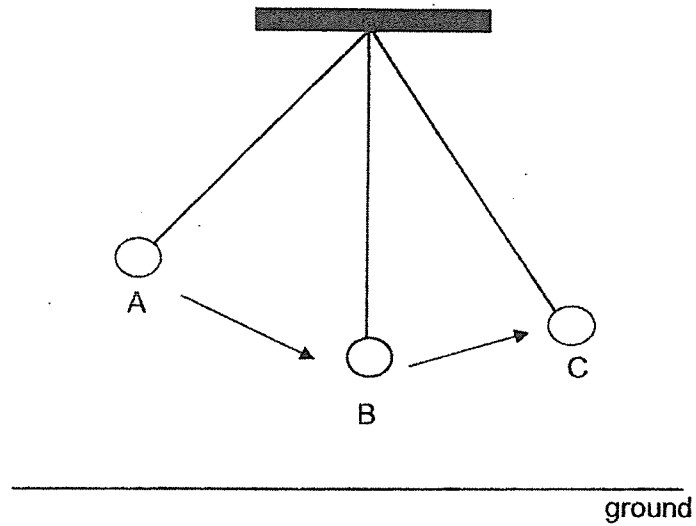

Which of the following graphs correctly depicts the changes in the gravitational potential energy (G.P.E) and kinetic energy (K.E.) of the ball from A to C?

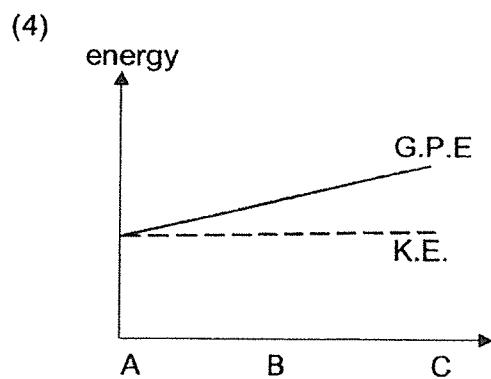
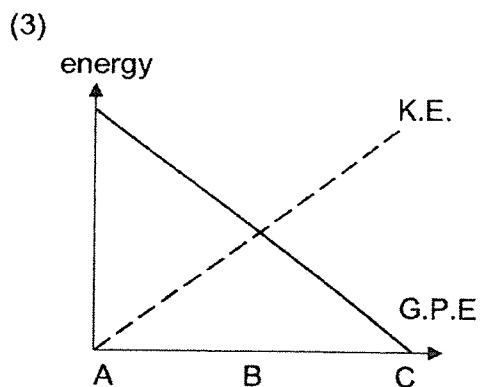
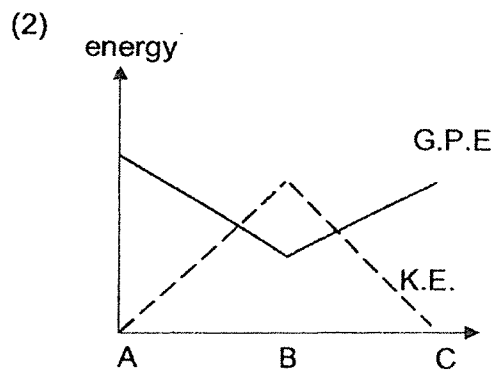
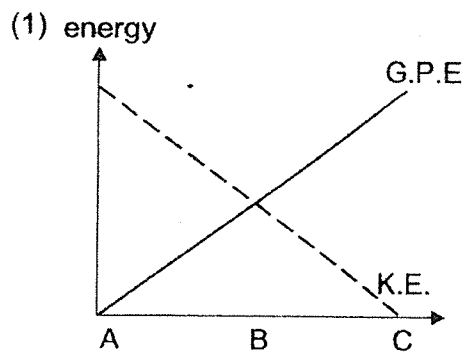

- 26 Agnes set up an experiment as shown below using two bars, R and S, which have a mass of 50 g each.

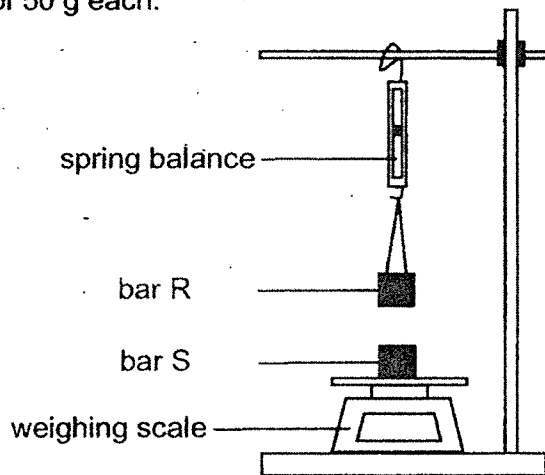

The table below shows the readings on the weighing scale and spring balance when the bars were arranged as shown above.

Reading on spring balance	Reading on weighing scale
less than 50 g	more than 50 g

Agnes made the following statements based on what she observed from her experiment.

- A R and S are both magnets.
- B R and S are repelling each other.
- C R and S are attracted to each other.
- D R is magnetic and S is non-magnetic.

Which of the statements are definitely correct?

- (1) A and B only
- (2) A and C only
- (3) A, B and C only
- (4) A, B and D only

- 27 The diagram below shows a coconut fruit that fell from a coconut tree, landed on the ground and subsequently dispersed and float on the seawater.

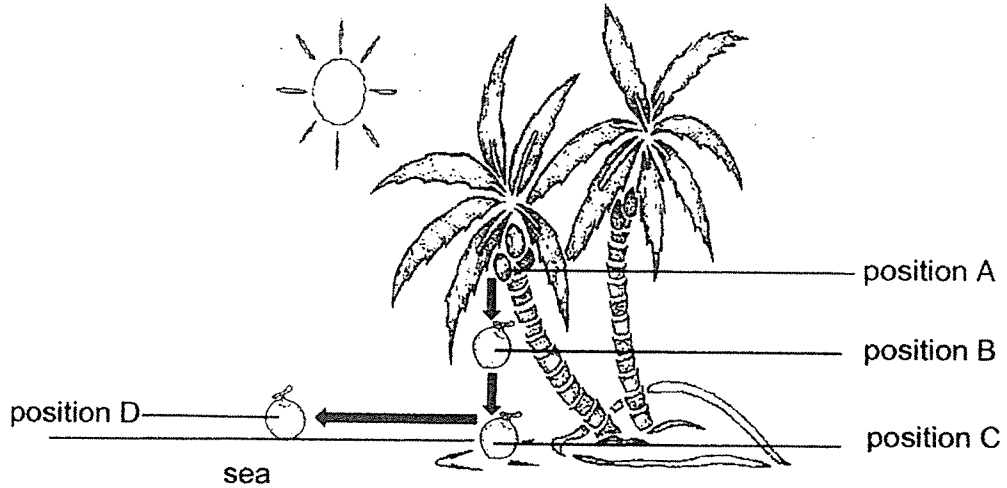

At which positions is gravitational force acting on the coconut fruit?

- (1) A and B only
- (2) A and C only
- (3) B, C and D only
- (4) A, B, C and D

- 28 The diagram below shows a magnet holding a sheet of paper in place on the whiteboard.

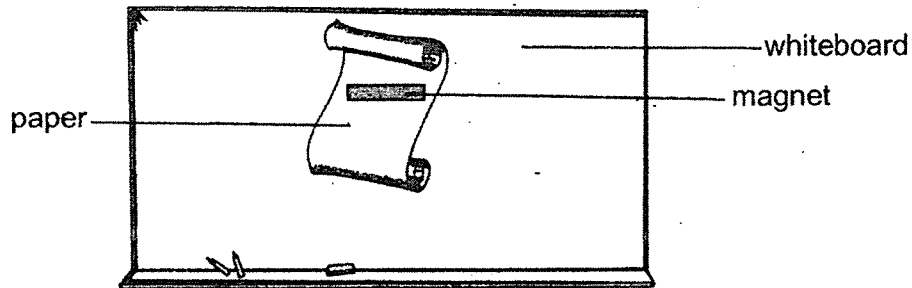

Jayden added a metal clip to the paper. After a while, he observed that the paper slid and fell to the ground. The arrow below shows the direction of the fall.

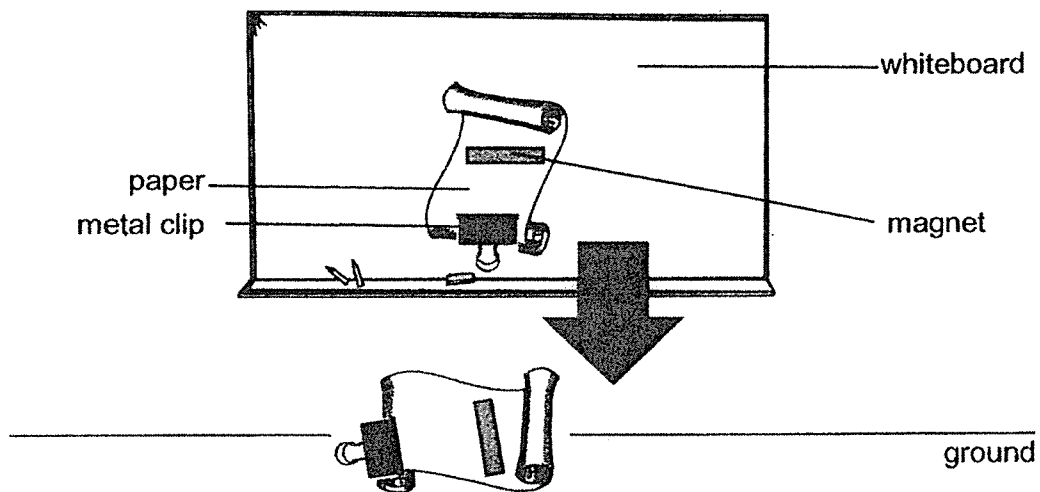

Which of the following statements correctly explains Jayden's observation?

- (1) There was magnetic force of attraction between the paper and the magnet.
- (2) Magnetic force of attraction between the magnet and the paper was too weak to hold the weight of the metal clip.
- (3) Frictional force between the magnet and the paper was greater than the total weight of the paper and the metal clip.
- (4) Gravitational force acting on the paper and the metal clip was greater than the friction between the paper and the surface of the whiteboard and the magnetic force of attraction between the magnet and the whiteboard.



NAN HUA PRIMARY SCHOOL
MID-YEAR EXAMINATION 2021
PRIMARY 6

SCIENCE

BOOKLET B

12 Open-ended questions (44 marks)

Total Time for Booklets A and B : 1 hour 45 minutes

INSTRUCTIONS TO CANDIDATES

1. Write your name and index number in the space provided.
2. Do not turn over the page until you are told to do so.
3. Follow all instructions carefully.
4. Answer all questions.
5. Write your answers in this booklet.

Marks Obtained

Section B

	/ 44
--	------

Name: _____ () Class: P 6 _____

Date : 11 May 2021

Parent's Signature: _____

Section B: (44 marks)

For questions 29 to 40, write your answers in the spaces provided.

The number of marks available is shown in brackets [] at the end of each question or part question.

29 The diagram below shows the human reproduction system.

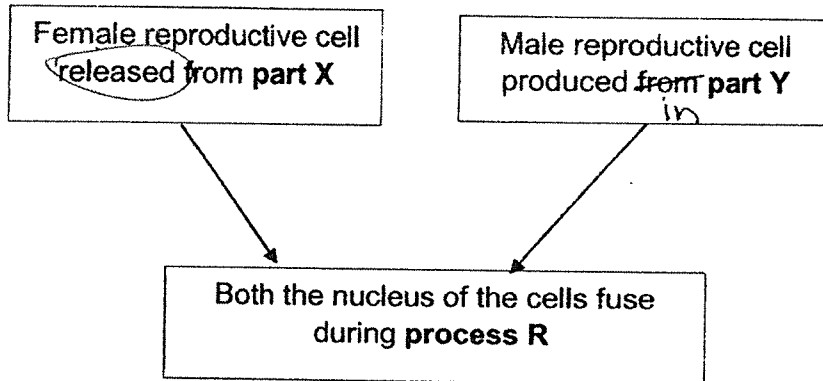

(a) Name an instrument that can be used to observe the parts of the female and male reproductive cells clearly. [1]

(b) Identify parts X and Y and process R. Fill in the table below. [2]

Part X	Part Y	Process R

(c) The diagram below shows the female reproductive cell. Label the part which the head of the male reproductive cell must pass through before process R can occur. [1]



2

Score	4
-------	---

- 30 Linus goes to the gym and decides to run on a treadmill. The graph below shows how Linus's heart rate changes with the speed at which he runs.

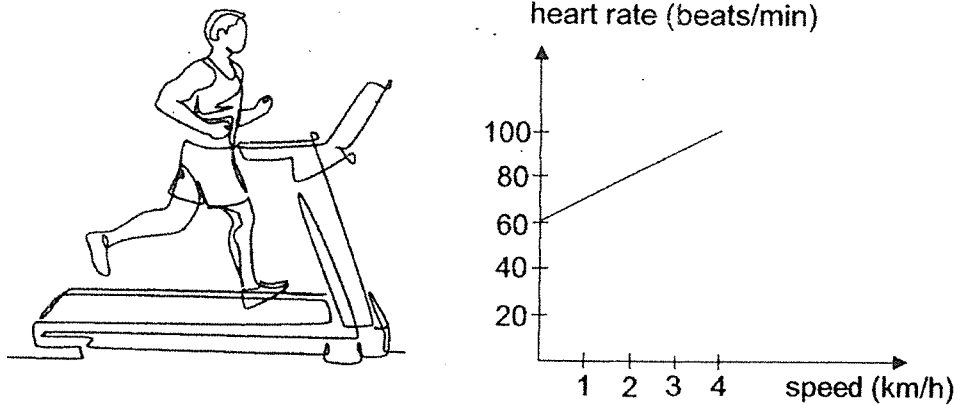

- (a) State the relationship between his heart rate and the speed at which he runs. [1]

- (b) Explain why this relationship in part (a) is observed. [2]

- (c) Linus stopped running and rested for 1 hour. Based on the graph, predict his heart rate after he rested for 1 hour. [1]

Activity	Rested for 1 hour
Heart rate (beats/min)	

Score	4
-------	---

- 31 David set up an experiment in a dark room as shown below. He wanted to find out how the number of bubbles given out by the water plant changes when **distance d** changes.

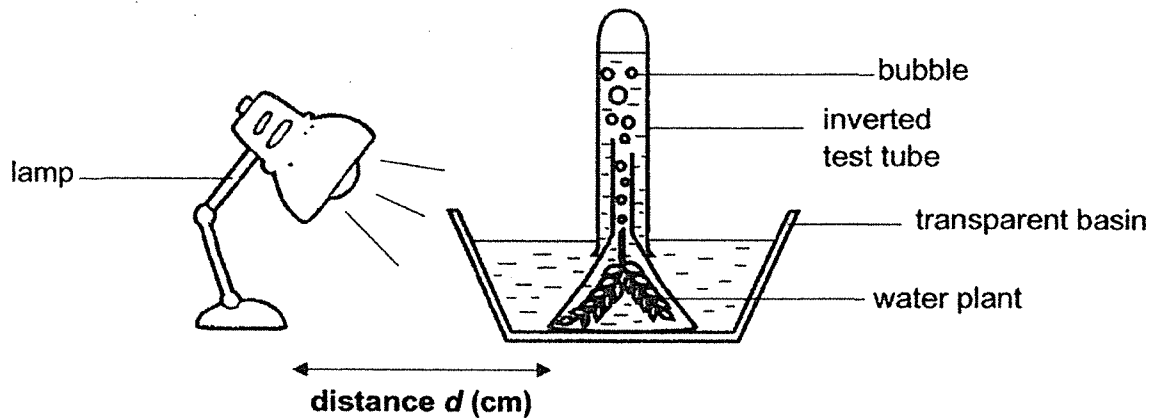

The result of his experiment was recorded as shown below.

distance d (cm)	Number of bubbles produced per minute
5	48
10	37
15	26

- (a) Identify the measured variable (dependent) in this experiment. [1]

- (b) What do the bubbles contain? [1]

- (c) Why did David carry out the experiment in the dark? [1]

- 32 Alice observed some organisms living near the pond and drew a food chain as shown below.

plant P → insect X → frog

She also noticed many tadpoles in the pond. There were many insects around plant P.

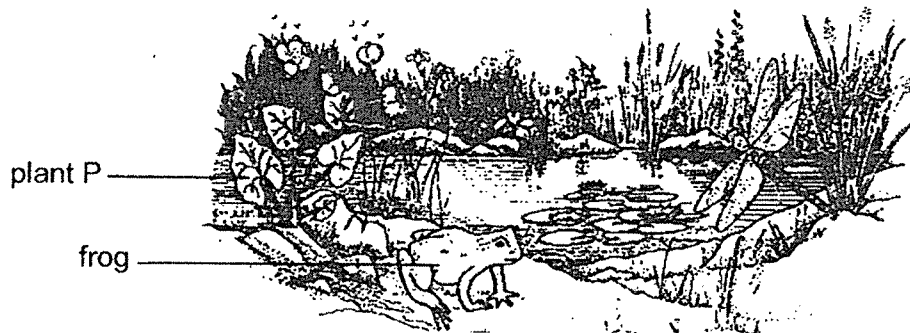

- (a) Based only on the information above, suggest two advantages for the frog to live near the pond. [2]

Advantage 1:

Advantage 2:

- (b) What role does plant P play in the food chain? [1]

Continue to next page

Score	
	3

(c) Predict how the population of plant P would change when the frog population increases. Explain your answer. [2]

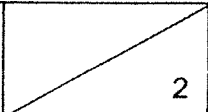
Score	
	2

33 The table below shows the relationships between four organisms.

Organism	Food relationships with other organisms
A	feeds on B
B	feeds on D
C	feeds on B and D
D	makes its own food

(a) Based on the table, which organism is a plant-and-animal eater? [1]

(b) Based on the table, draw a food web to show the relationship between the four organisms A, B, C and D, in the box below. [1]

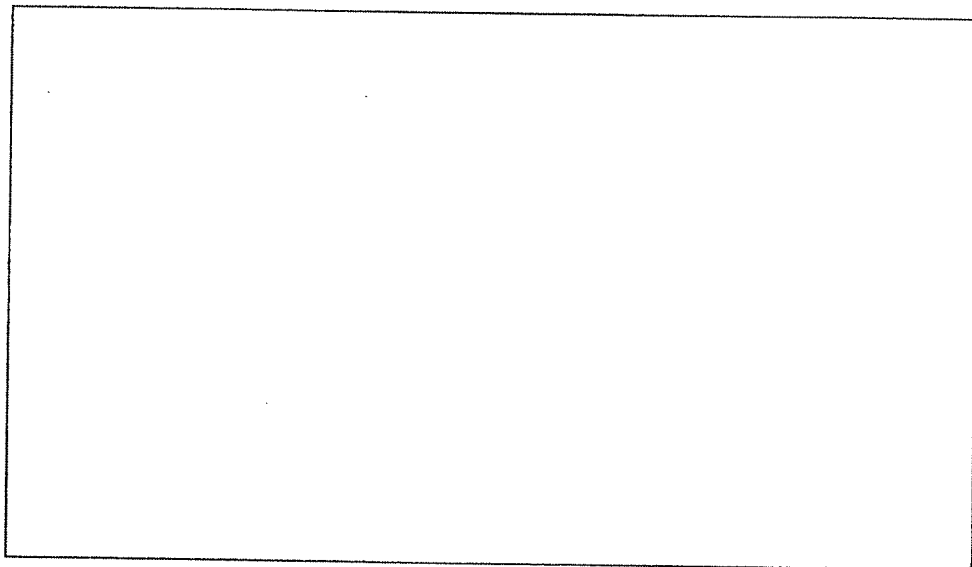

(c) Which organism in the food web in part (b) would be the most affected if there was a disease that caused the population of organism B to decrease?

[1]

Score	3
-------	---

- 34 Nick conducted an experiment using the set-up below. He placed a container of water on top of a strip of material X. Then he measured the distance between the highest and lowest points of the strip and labelled as **distance h** .

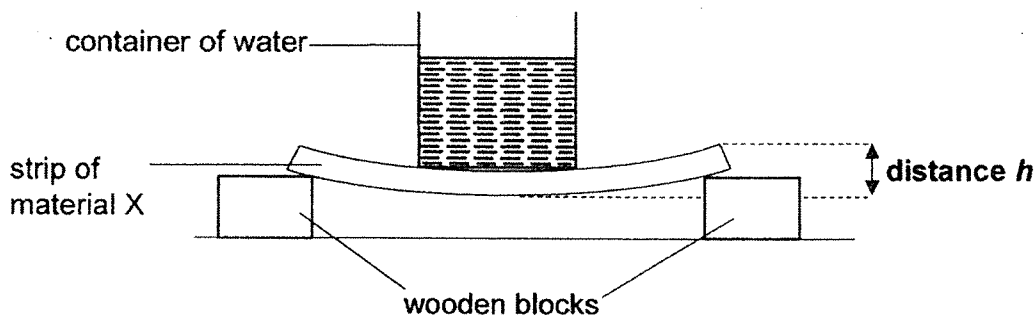

He repeated the same experiment with materials Y and Z and recorded the results as shown in the table below.

Strip of material	Amount of water added into the container (cm ³)	Distance h (cm)
X	40	2
Y	40	4
Z	40	1

- (a) State **two** variables of the strips that must be kept the same in order for the test to be a fair one. [1]

- (b) Based on the information in the table, which material, X, Y or Z, is most suitable for making a food tray? Explain your answer. [2]

Continue to next page

- (c) Nick repeated his experiment with materials X, Y and Z. However, in order to keep the **distance h** the same, he added different amounts of water into the container.

Name the material with the most and least amount of water added. [1]

Most amount of water: Material _____

Least amount of water: Material _____

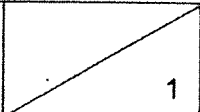
Score	
-------	---

- 35 The diagram below shows two similar food steamers, A and B. The same amount of water was poured into the water container at the bottom of each steamer and both steamers were turned on at the same time to start steaming the food.

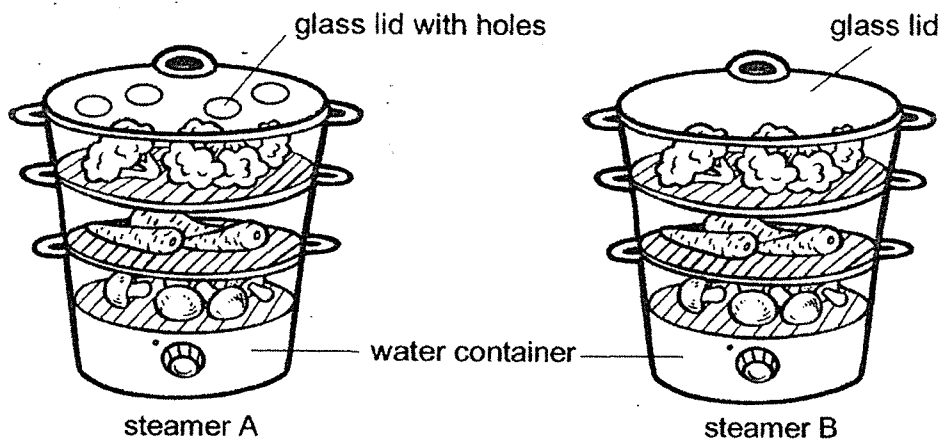

After some time, the water in steamer A dried up faster than steamer B.

- (a) Explain why the water in steamer A dried up faster than steamer B. [2]

- (b) A third steamer, C, which was similar to steamer B, had a metal lid. Which steamer, B or C would have water droplets formed on the lid faster? State a reason for your choice. [1]

Score	
	3

- 36 Most airlines only allow passengers to check in their hand carry bags with a maximum mass of 7kg. The diagram below shows the system used to detect a luggage if it exceeds the limitation. A bell would ring when the mass of luggage is exceeded.

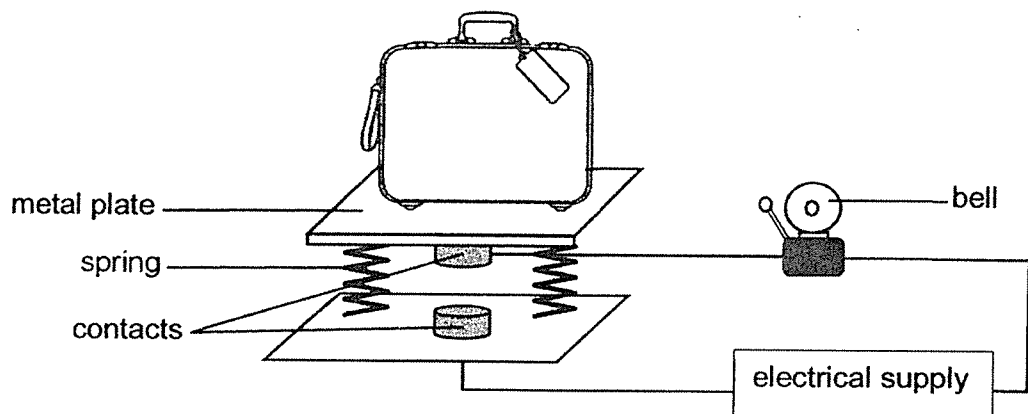

- (a) State the property of the material used to make the contacts which allows the system to work. Explain your answer. [2]

- (b) Suggest one way how the system can be improved such that passengers can now be allowed to carry a luggage with a maximum mass of 9 kg. Explain your answer. [2]

Score	4
-------	---

- 37 Mr. Tan walked past a lighted lamp post one night and observed that he cast shadows of different lengths when he stopped at positions, P, Q and S.

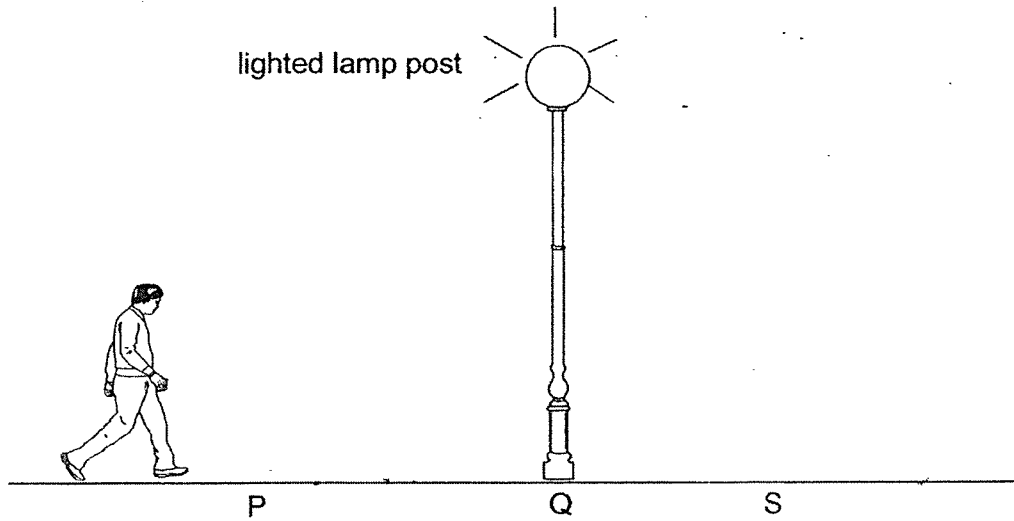

- (a) Label 'X' on the straight line in the above diagram to indicate where the shadow of Mr. Tan was cast when he stopped at position S. [1]
- (b) Explain how his shadow at 'X' was formed. [1]
-
- (c) In the table below, arrange the length of his shadows at positions P, Q and S from the shortest to the longest. [1]

Shortest → Longest		

Score	3
-------	---

- 38 Amanda made a simple set-up of a hydro-electric power station as shown in the diagram below.

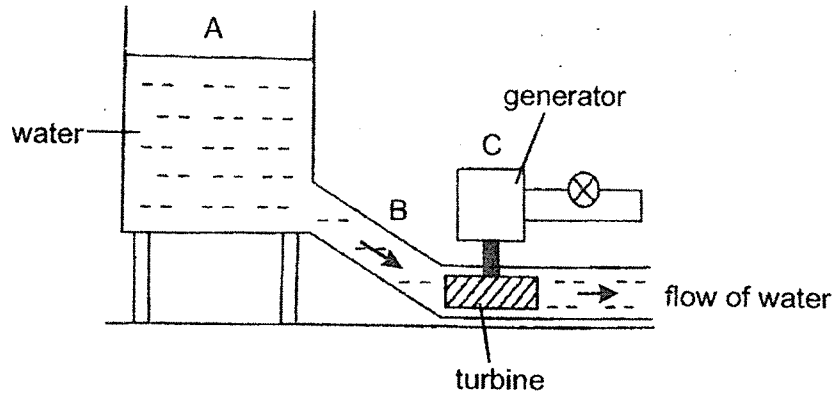

The turbine is connected to the generator and when the water flows, it turns the blades in the turbine and electricity will be produced by the generator.

- (a) Fill in the boxes to show the energy changes. [1]

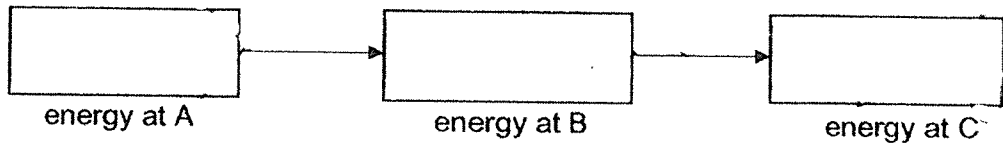

- (b) Actual hydro-electric power stations are built on a large scale such that water is of a greater height above the turbine as compared to the simple set-up.

What is the advantage of building hydro-electric power station in this way?
Explain your answer. [2]

- 39 The diagram below shows a toy. Part P can be pulled back to different positions. The ball in front of the spring will shoot towards the target when part P is released.

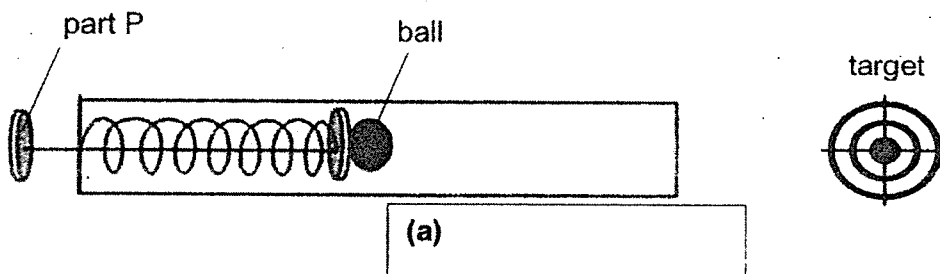

- (a) In the diagram above, draw an arrow in the box to show the direction of the force acting on the ball when it shoots towards the target. [1]
- (b) Besides the pushing force acting on the ball when it travels to the target, name another force acting on the ball. [1]
-

Continue to next page

Score	2
	2

- (c) Kevin pulled part P to different positions (A and B) as shown in the diagram below. He observed that the ball which was pulled to position A, travelled distance, d_a , ^{and} missed the target while the ball which was pulled to position B, travelled distance d_b , ^{and} hit the target.

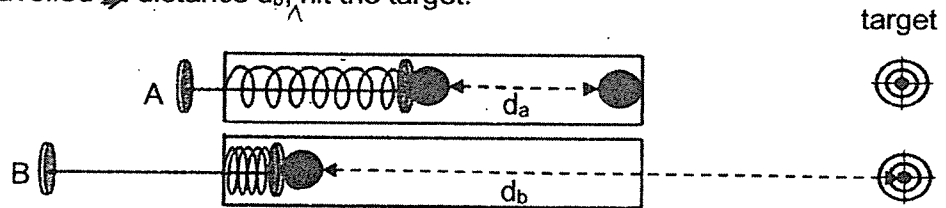

He recorded his observations in the table below.

Position	Did the ball hit the target?
A	No
B	Yes

Explain the difference in the results using the concept of forces. [2]

- 40 Jason set up an experiment as shown below. He added 20 g weights, one at a time, to the weight hanger at the end of the string and counted the number of weights it could hold before the wooden block start to move.

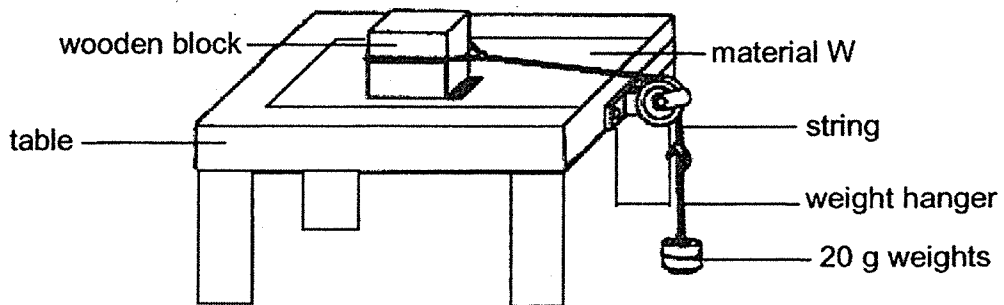

He repeated the experiment using different types of materials, X and Y, laid on the table surface and recorded his results in the table below.

material	Number of weights added before the wooden block started to move
W	10
X	5
Y	15

- (a) Suggest what Jason can do to increase the reliability of his results. [1]

- (b) Explain, in terms of forces, why the wooden block started to move when a certain number of weights was added to the weight hanger. [1]

Continue to next page

- (c) Brick layers spent long hours under the hot sun at a construction site laying bricks. They wear special gloves when handling the bricks to prevent the bricks from slipping.

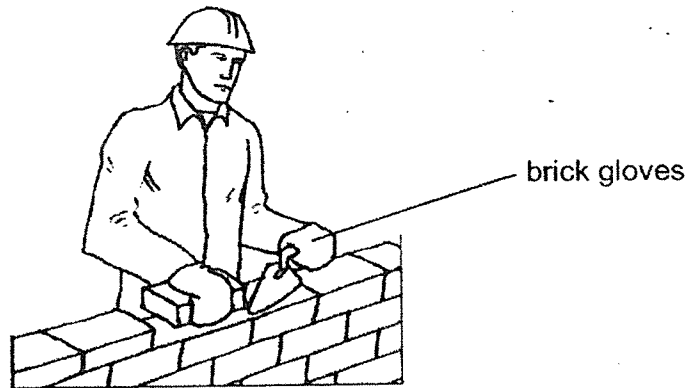

Based on the results in the table on page 16, which surface, W, X or Y, is most suitable to make the outer surface of the gloves? Explain your answer.

[2]

End of Paper

Score	
-------	---